

II B. Tech I Semester Supplementary Examinations, May - 2019
MECHANICS OF SOLIDS
 (Com to ME, AE & AME)

Time: 3 hours

Max. Marks: 70

- Note: 1. Question Paper consists of two parts (**Part-A** and **Part-B**)
 2. Answer **ALL** the question in **Part-A**
 3. Answer any **FOUR** Questions from **Part-B**

PART - A

1. a) What do you mean by “a bar of uniform strength”? (2M)
- b) What are the General sign conventions for shear force and bending moment in general? (2M)
- c) A wooden beam of 100 mm wide and 150 mm deep is simply supported over a span of 4 m. If shear force at a section of the beam is 4500 N, find the shear stress at a distance of 25 mm above the Neutral axis? (3M)
- d) What is a Macaulay’s method? Where it is used? (2M)
- e) Define the term Polar Modulus? Find the expression for polar modulus for a solid shaft? (3M)
- f) What do you mean by Lamé’s equations? (2M)

PART - B

2. Two vertical rods one of steel and other of copper are each rigidly fixed at the top and 50 cm apart. Diameters and lengths of each rod are 2 cm and 4m respectively. A cross bar fixed to the rods at the lower end carries a load of 5000 N such that the cross bar remains horizontal even after loading. Find the stresses in each rod and the position of the load on the bar. Take E for steel = $2 \times 10^5 \text{ N/mm}^2$ and E for copper = $1 \times 10^5 \text{ N/mm}^2$. (14M)
3. A simply supported beam of length 10 m carries the uniformly distributed load and two point loads as shown fig. Draw the shear force and bending moment diagrams for the beam. Also calculate the maximum bending moment. (14M)

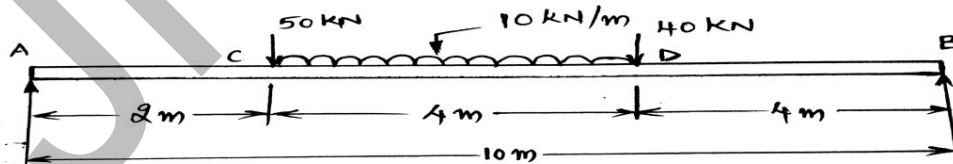

Code No: R1621032

R16

SET - 1

4. The cross-section of a beam is shown in fig. The beam is made of material with permissible stress in compression and tension equal to 100 Mpa and 140 Mpa respectively. (14M)

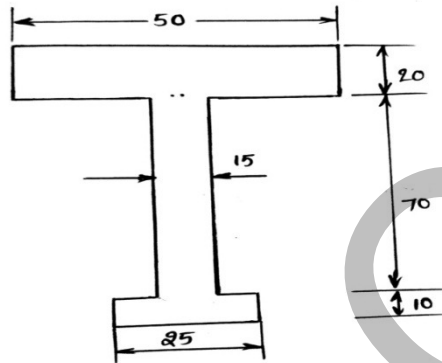

Calculate the moment of resistance of the cross-section, when subjected to a moment causing compression at the top and tension at the bottom.

5. A beam of length 6 m is simply supported at its ends. It carries a uniformly distributed load of 10 KN/m as shown in fig. Determine the deflection of the beam at its midpoint and also the position and the maximum deflection. Take $EI = 4.5 \times 10^8 \text{ N/mm}^2$. (14M)

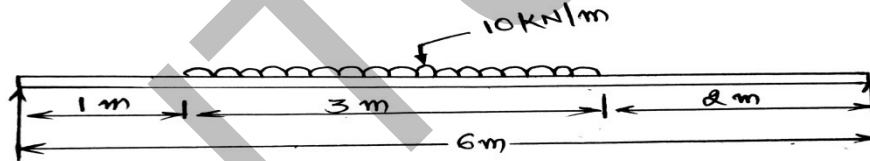

6. A closed cylindrical vessel made of steel plates 4 mm thick with plane ends, carries fluid under a pressure of 3 N/mm^2 . The diameter of the cylinder is 25 cm and length is 75 cm, calculate the longitudinal and hoop stress in the cylinder wall and determine the change in the in diameter, length and volume of the cylinder. Take $E = 2.1 \times 10^5 \text{ N/mm}^2$ and Poisson's ratios is 0.286. (14M)
7. Determine the crippling load for a T- section of dimensions 10 cm x 10 cm x 2 cm and of length 5 m when it is used as strut with both of its ends hinged. Take young's modulus, $E = 2.0 \times 10^5 \text{ N/mm}^2$. (14M)

